

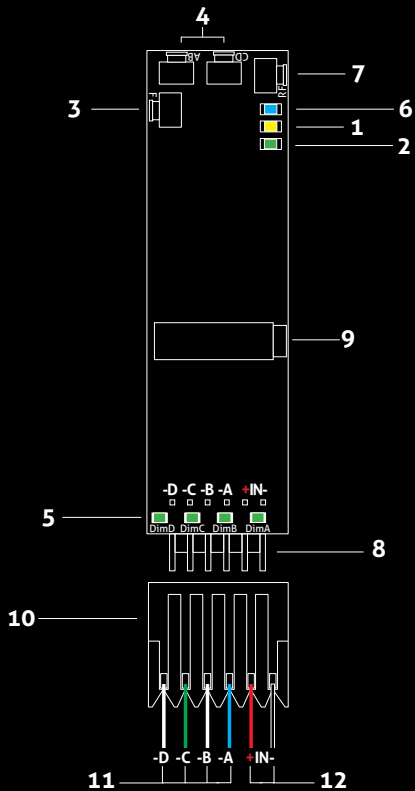

LumenDimM4micro
Miniature Four-Channel Wireless Dimmer
Quick Start Guide

Rev. 1.1A



RC4 LumenDimM4micro

1. DMX Data Indicator
2. Function and COP ² Indicator
3. Function Button
4. SetAB and SetCD Buttons
5. DimA - DimD Indicators
6. RF Connect Indicator for Transmitter Linking
7. RF Connect (Link) Button
8. Male Connector Pins for Power In and Dimmer Outputs
9. DMX/RDM In/Out Data Port
10. Disconnectable Female IDC Connector ¹ for Power In and Dimmer Outputs
11. Load Connection Wires (DimB +/- DimB +/-)
12. Power Connection Wires (DCin +/-)

1. Connector is Amp MTA-100-Series, 0.1" pin spacing. Shell color indicates wire gauge. Red shell is for 22 AWG wire, Amp connector P/N 3-641190-6. Numerous alternatives are available, each with different P/Ns. Use the correct shell for the wire you are using. Amp also supplies crimping tools for these connectors. One 22 AWG connector assembly is included with each LumenDimM4micro. Additional cable assemblies are available from RC4 Wireless.

2. COP means "Computer Operating Properly." This indicator always shows a blink pattern, proving that internal firmware is running. Different patterns indicate various modes and advanced settings.

LumenDimM4micro Quick Start Guide

This guide will get you started using your RC4 LumenDimM4micro. Most LumenDimM4micro users will find all the information they need right here.

Your LumenDimM4micro also has a wide variety of expanded features for advanced users. You can find out more about all of them in the RC4 Knowledge Base at <http://rc4.info>.

Registering Your Product

Registering your LumenDimM4micro is quick and easy. After registration, you'll be notified of new firmware updates, and warranty claims can be resolved more quickly.

Please complete your registration at:
www.rc4wireless.com/support/register/

LumenDimM4micro System Components

To use your LumenDimM4micro wireless dimmer you will need:

- A DMX lighting console.
- A LumenRadio CRMX-compatible wireless transmitter like the RC4 LumenDimIO or the LumenRadio TX1.
- A battery or DC power supply for the dimmer and loads you will be operating with it.

MTA-100 Connector Shell Color and Wire Gauge Matter

The 6-pin connector on the LumenDimM4micro is the Amp MTA-100-Series, with 0.1" pin spacing. These are Insulation Displacement Connectors (IDC). An Amp MTA-100 tool is used to insert the wires.

One 22 AWG red-shell wire-tail assembly is provided with each LumenDimM4micro. Additional cable assemblies are available from RC4.

The shell color of MTA connectors indicates the wire gauge it is designed for. Red shells, Amp P/N **3-641190-6**, are for 22 AWG wire. Each different wire gauge uses a connector with a different color and P/N. Use the correct shell for the wire you are using.

Connections to the wires on RC4 wire-tail connector assemblies can be made by soldering, crimp connectors, wire caps, or other joiners. Be sure to cover soldered connections with tubing or tape to avoid accidental short circuits.

Performing a Factory Reset

If someone else has used your LumenDimM4micro, or you just want to get back to a known configuration, performing a factory reset is easy:

Power on the device. The green COP indicator will be blinking.

Press and hold Func, briefly tap (press and release) the SetAB button, then release Func. Several indicators will blink together to confirm that factory settings are restored.

NOTE: This does NOT affect transmitter linking. You must intentionally unlink to disconnect from a previously linked transmitter.

PRO TIP: If you are not sure what mode or setting you may have selected, you can always get back to a known starting point by returning to factory default.

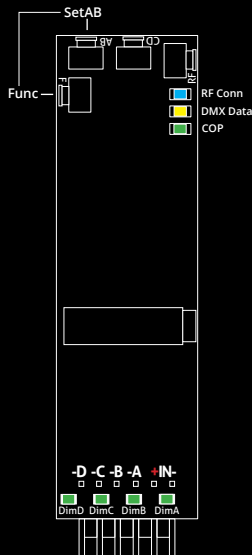

Unlink the LumenDimM4micro

If the blue RF Connect LED on the LumenDimM4micro blinks continuously, it is looking for a transmitter that it was previously linked with.

To unlink it, press and hold RF Connect for several seconds until the blue LED goes off and stays off.

If the RF Connect LED remains on, or is blinking, repeat the process until it stays off.

When the RF Connect LED is off, the LumenDimM4micro is ready to be linked to your transmitter.

Link status is not affected by performing a Factory Reset. You must intentionally unlink to disconnect from a previously linked transmitter.

NOTE: When using a wired RDM controller plugged into the miniplug DMX connector, wireless DMX data must be stopped. This can be done by unlinking, turning off the wireless transmitter, or disconnecting the wired DMX data going into the transmitter.

Linking Transmitter and Receiver

In this example, we're using an RC4 LumenDimIO transmitter. Have both devices powered on. Put the LumenDimIO Mode switch in the transmit position. Connect a DMX data source to the XLR data input on the LumenDimIO.

Tap the Link button. This button is recessed under the small slot to the right of the blue RF Connect LED. Tap it with a small screwdriver or the end of a bent paperclip.

The blue RF Connect LEDs on both devices will flash for several seconds and then remain on, indicating that they are linked.

NOTE: If DMX data is not present at the transmitter, the blue LED will blink slowly rather than staying on.

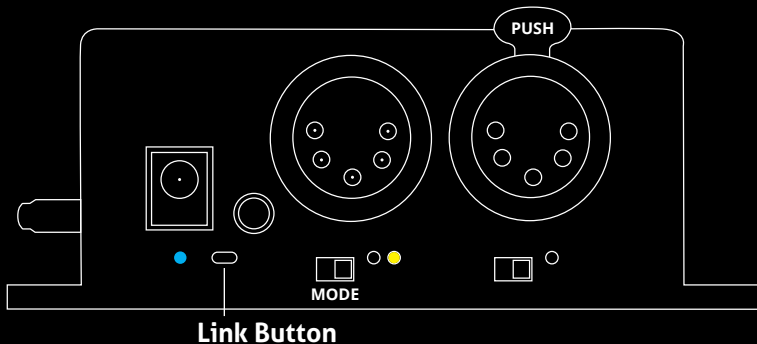

Test the Wireless Link with Default Address Settings

When you receive your new LumenDimM4micro, or after restoring default settings, it will be set to DMX addresses 1 through 4 for dimmer A, B, C, and D.

Before changing any dimmer settings, play with the DMX levels for these addresses and see your wireless dimmer outputs work.

The DimA, DimB, DimC, and DimD indicators are directly connected to dimmer outputs to show you exactly what the dimmers are doing.

Setting the DMX Address

Assigning DMX channels and dimmer curves is easy using RC4 OneTouch™:

On your DMX lighting console, bring up one dimmer (DMX output channel) that will be your LumenDimM4micro starting address. For example, if you want your first LumenDimM4micro dimmer on DMX channel 60 with a curve that is optimized for LEDs, bring up 60 @ 30% at the console. Tap SetAB and the DimA indicator will come on at 30%.

The level of 30% selects one of several different curves. This one is optimized for LEDs. Other curves are explained on Page 13.

Subsequent Channel Assignment

When you set DimA, all 4 dimmers are automatically set sequentially. For example, if you have set DMX channel 60 to DimA, DimB is now assigned to channel 61, DimC is Channel 62, and DimD is 63.

Non-Sequential Channel Assignment

The two pairs of dimmers do not have to be sequential.

You can use RC4 OneTouch™ with the SetCD button to set the second pair of dimmers to their own addresses. For example, if you want DimC to be set to DMX address 11, bring up 11 @ 30% (for the LED curve) at the board and press the SetCD button. This will also assign DimD to channel 12.

Remember: SetAB assigns all 4 dimmers sequentially. The other Set button works only for dimmers C and D. Always use SetAB first, then use SetCD if needed.

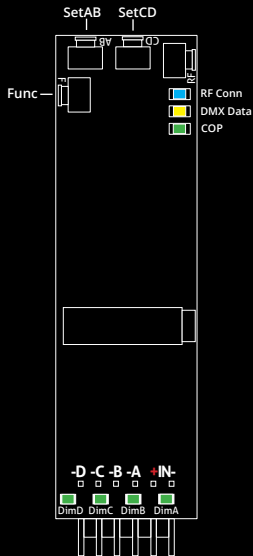

Connecting Your Lamps, LEDs, Motors and More*

To really use your LumenDimM4micro, you must connect a lamp, LED, motor, or other load to each dimmer. When you're connecting anything to your LumenDimM4micro, be sure that the LumenDimM4micro is powered down. Connect everything first, double-checking your wiring, be certain connections are properly protected from short circuits, then turn on power.

Connections should be made to an MTA-100 connector. Attach the connector to the LumenDimM4micro after wiring is completed and checked, then apply power.

* The LumenDimM4micro can control a variety of devices including solenoids, relays, servo motors, and much more.

One 22 AWG MTA-100 connector assembly is included with each LumenDimM4micro. Find additional information about MTA-100 connectors on page 5.

NOTE: All positive (+) connections are made directly to the power source. Dimming is implemented on the negative (-) side of the circuit.

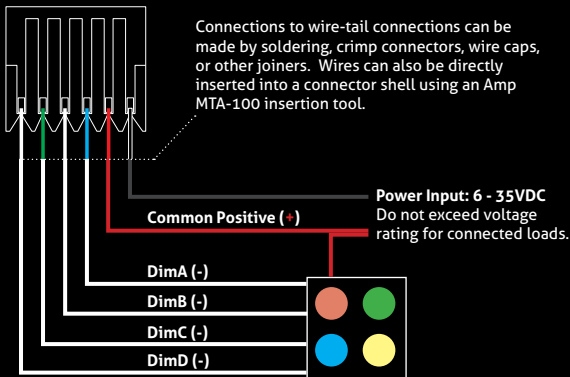

Dimming and Controlling Multicolor LEDs

The illustration on the previous page shows a 4-color LED device with 5 wires: one for the 12V common positive (+), and four wires for the negative lead of each color. The common positive color is shown as red, but may vary.

Dimming happens on the negative (-) terminals. There are no positive (+) output connections on the LumenDimM4micro. The positive for the dimmer and all load devices should be connected directly to the power source.

Cross-Fade Mode for Warm/Cool White Control

The LumenDimM4micro includes a color Cross-Fade mode (sometimes called X-Fade). Cross-fading between warm and cool white light sources produces a range of color temperatures to find the exact rendering of white that you need.

In Cross-Fade mode, two separate hardware pairs operate independently (but can be assigned to the same DMX channels). For each pair, one DMX channel controls color temperature, and the next channel controls total brightness. The selected color temperature does not change when the level is adjusted.

Cross-Fade and many other features can be explored further at <http://rc4.info/> or by asking us for help at support@rc4wireless.com.

Choosing Other Dimmer Curves or Profiles

The LumenDimM4micro default is the ISL dimmer curve, which is best for LEDs. This is also the curve that is selected with RC4 OneTouch™ when the DMX level is at 30%.

There are dimmer curves for different kinds of lamps, motors, and more. Detailed information can be found online by searching dimmer curves at <http://rc4.info/>.

The most common curves are selected using these DMX channel levels and RC4 OneTouch™ with the Set buttons as outlined on page 9:

<i>Non-Dim</i>	100% (80% or higher) Use for relays, solenoids, air valves, etc.
<i>Linear</i>	70% (60 - 79%) For incandescent, halogen, tungsten lamps.
<i>ISL Fast</i>	50% (40 - 59%) For LEDs when fast blinks and flashes are required. RC4 Digital Persistence™ is disabled.
<i>ISL Slow</i>	30% (20 - 39%) Best for typical LED applications, with RC4 Digital Persistence™ For super smooth 19-bit dimming. (default setting)

Advanced Features

The LumenDimM4micro is a multifaceted device for users of all experience levels. The features below can be explored further at <http://rc4.info/> or by asking us for help at support@rc4wireless.com:

- Using a small adaptor cable, the LumenDimM4micro can be used as a wireless data receiver to deliver DMX to other devices, or as a wired DMX dimmer. The miniplug port can work as wired DMX in or out!
- When using the LumenDimM4micro for motion picture capture, PWM frequencies can be adjusted to avoid banding and other artifacts.
- The LumenDimM4micro has a wide variety of specialty dimmer curves to ring telephones, position servo motors, and more.
- HSL Mode allows color to be controlled as Hue/Saturation/Level.
- Using the RC4 Flkr Effects Engine™, you can create many unique effects including candle flicker, analog tv screen noise, welding spark, and much more.
- When you purchased your LumenDimM4micro, you selected either internal chip antenna, or external antenna via the U.FL connector. If you are comfortable with precision electronic soldering, ***you can change the antenna type yourself***. The LumenRadio TiMo RF module uses its on-board chip antenna if pins 5 and 6 are jumpered together. With no jumper, the TiMo will use the external U.FL connector by default. Go to the RC4 Wireless online Knowledge Base for more details. Adding or removing a jumper does not void the product warranty, but bad workmanship might. Ask us if you'd like a replacement product label after changing the antenna type. And don't hesitate to ask for assistance!

Caring for Your LumenDimM4micro

- The LumenDimM4micro is a circuit-board assembly without a protective case. ***This makes it more sensitive to damage by static discharge and accidental short circuits than devices with an enclosure.*** When wiring and installing this device in an application, take appropriate precautions for handling exposed electronics, including a grounded work mat and static discharge strap. *Failure caused by static damage is not covered under warranty.*
- **The LumenDimM4micro should not be used with AC power or with any voltage higher than 35VDC.** Doing so will severely damage the device and is extremely dangerous for the operator.
- Do not exceed the maximum total power handling of the LumenDimM4micro, which is 6A. That is 72W at 12V, 144W at 24V, shared across the four dimmer channels.
- Always use a fuse or circuit breaker at the source of power and always use an appropriate wire size for the fuse rating. For example, if using a 3A fuse, use wire that can safely carry 3A.
- The LumenDimM4micro should be kept away from excessive heat, cold, dust and moisture.
- Do not immerse in water or other fluids.
- Dimmers generate heat when operating. Allow space for air to move around the unit for cooling, especially when driving 5A or more.

The LumenDimM4micro is a high-power, high-current device. Failing to observe appropriate safety precautions can result in fire or other risk. RC4 Wireless cannot be held responsible or liable in such cases. Operate the LumenDimM4micro at your own risk.

Get in Touch

1-866-258-4577

1-919-229-9950

+44 (0)20 3289 8765

1-866-237-6641

Toll Free, North America

North Carolina, USA, Local

London, UK

Toll Free Fax, North America

Email: support@theatrewireless.com

Website: www.rc4wireless.com

Knowledge Base: <http://rc4.info>

We're here to help you at any time.

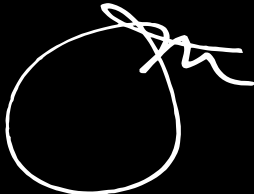

James David Smith

President and Chief Product Designer

RC4 Wireless